

Over
25
Years

Reinbold
Entsorgungstechnik



„BEAR“ FORCE AND RELIABILITY

SINGLE SHAFT SHREDDER

AZR 60 Primus



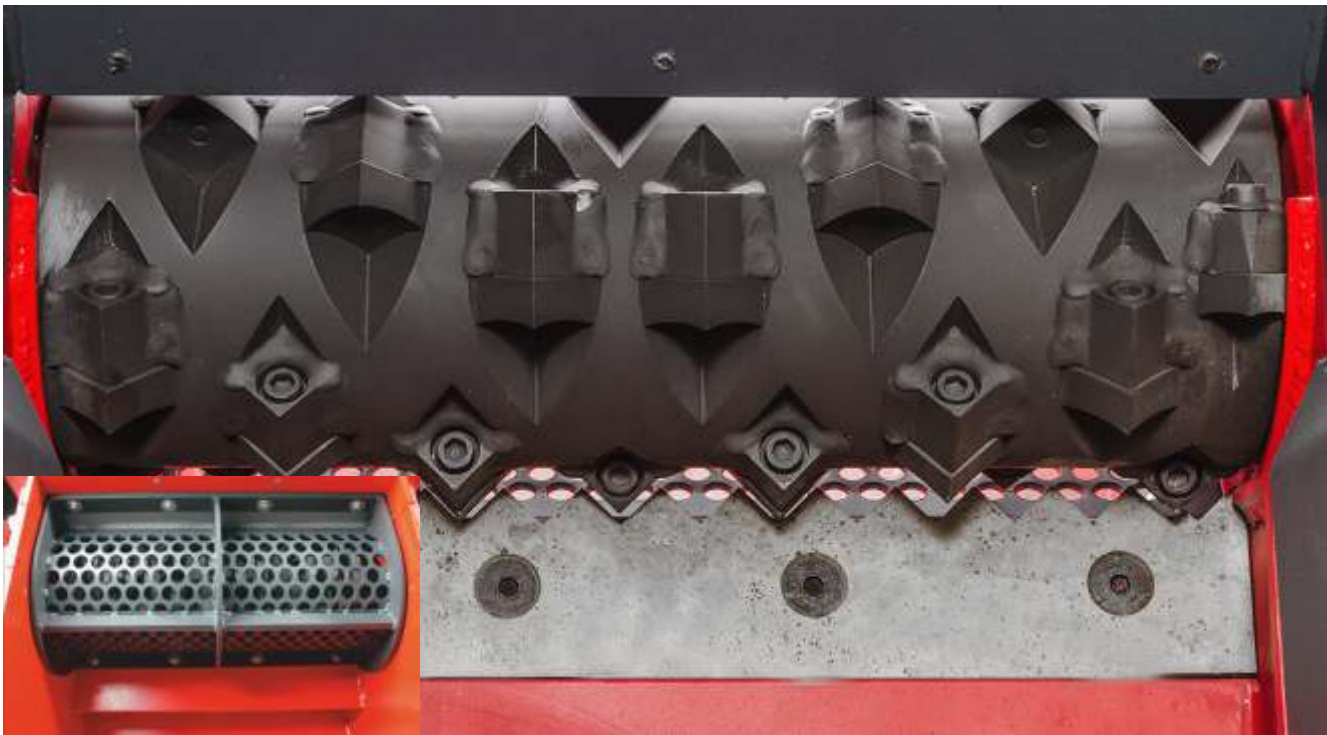

AZR 60 Primus material shredder

The powerful-shredder AZR 60 Primus, with its wide range of applications, can be shred many different wood materials such as softwood, chipboard, as well as paper and cardboard.

A special feature of the series AZR 60 Primus is the low noise and power consumption associated with low rotor speed.

The material is feeded to the hopper and crushed between the rotor blades and the fixed counter knife into chips. The chip size is determined by the screen perforation size. The PLC control switch off the machine automatically when the hopper is empty. The produced chips will be held for example by a screw conveyor from the machine and sent for thermal recovery. By bulky materials an enormous volume reduction is achieved.

- ▶ High output
- ▶ Easy to use and very reliable
- ▶ Compact, rugged steel construction
- ▶ Easy maintenance
- ▶ Low operating costs

Type	AZR 60 Primus	
Feed opening	(mm)	600 x 800
Hopper Volume	(m ³)	0.6
Throughput		according to material and screen
Rotor-Ø	(mm)	252
Rotor Speed	(UpM)	90
Power	(kW)	15 / 18.5
Knives	(Pcs.)	14 / 28 (Square cutting crowns 40 x 40 mm)
Screen Perforation	(mm)	10 - 50
Suction port-Ø	(mm)	160
Air speed	(m/sec)	28
Weight	(approx. kg)	1.300

The machine is also available with the circular blade V7 and / or circular blade V8

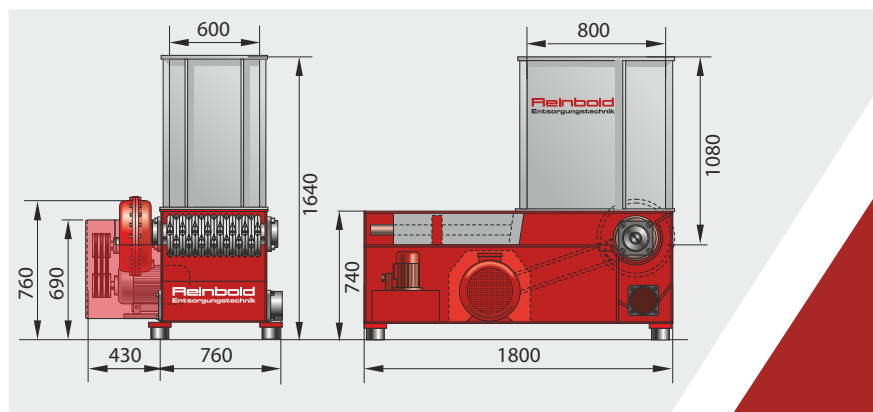

Reinbold Entsorgungstechnik

Robert-Mayer-Strasse 5
74360 Ilsfeld (Germany)

Phone: +49 (0) 7062 / 97885-0
Fax: +49 (0) 7062 / 97885-50

info@reinbold.de
www.reinbold.de

Your dealer:

